

A Series

Welcome OEM Order



Combining Pipe Racking & Green Frame System

GAJ28-H01

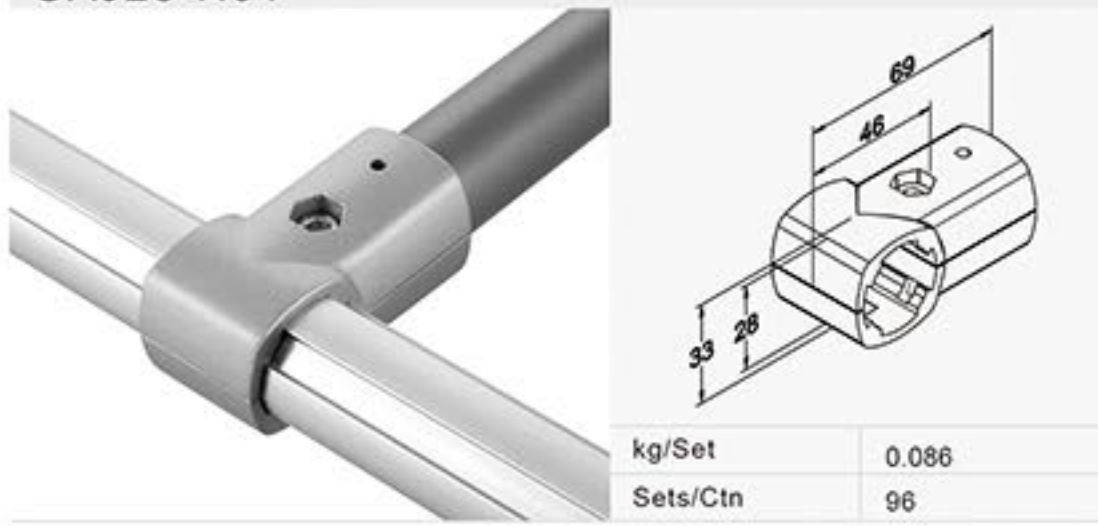

GAJ28-H01A

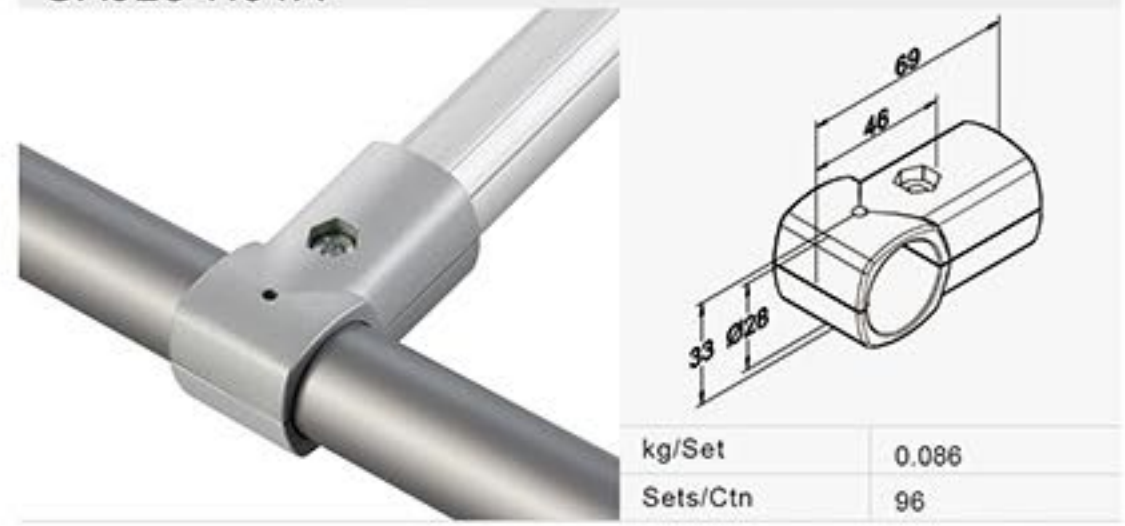

GAJ28-H02



GAJ28-H03

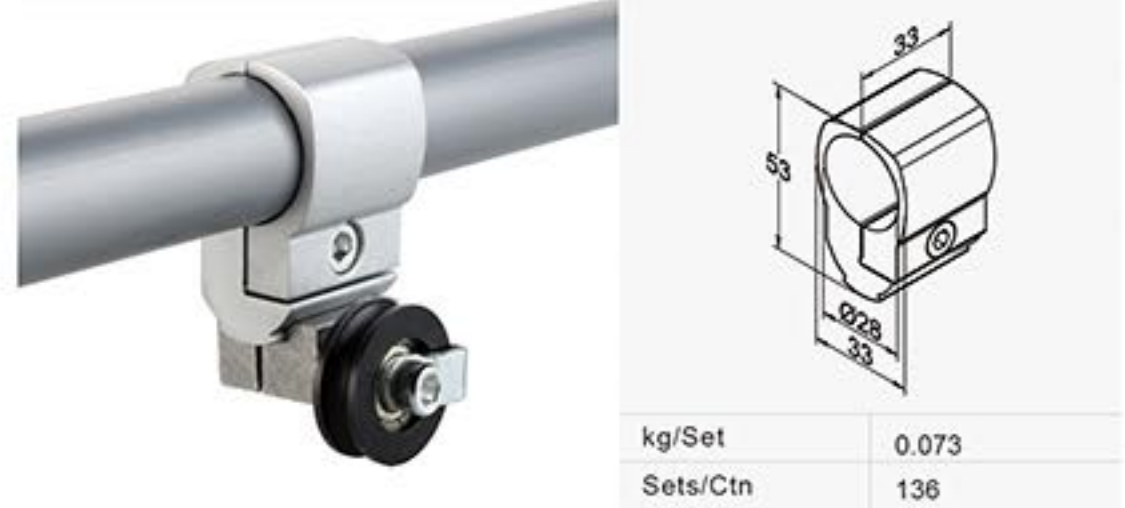

GAJ28-H04



GAJ28-H05

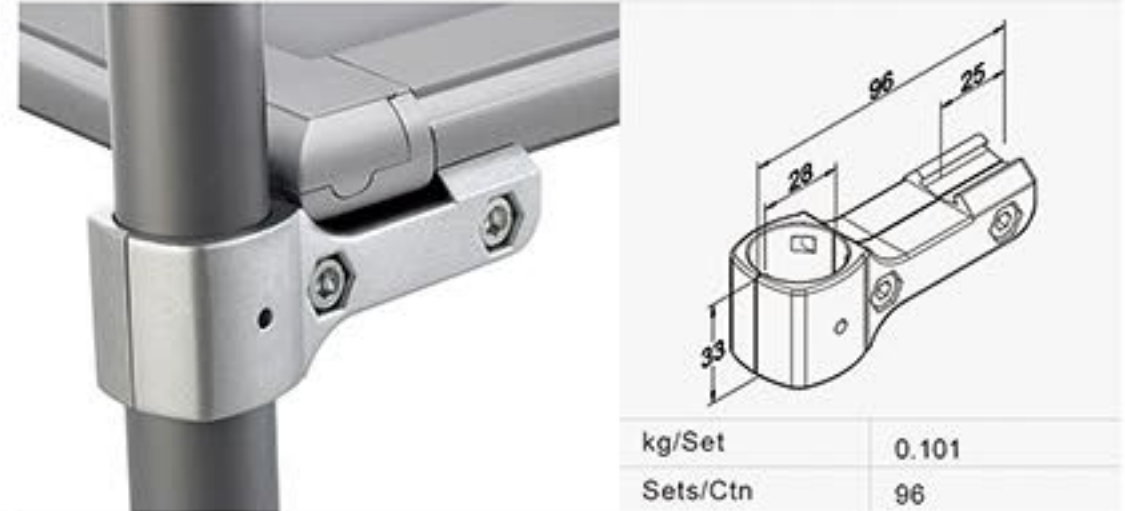

GA28-14A

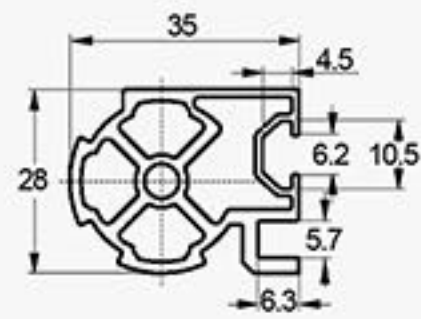

kg/m	0.840
m/Pc	4
m/Bdl	48

GA28-15A

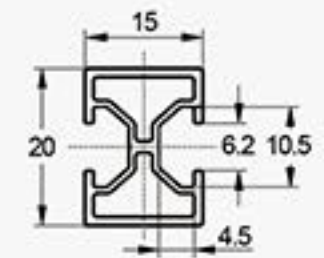

kg/m	0.244
m/PC	4
m/BDL.	48

GA28-16A

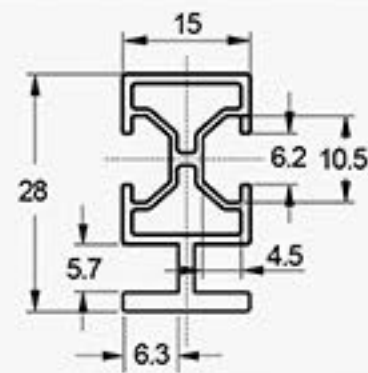

kg/m	0.368
m/Pc	4
m/Bdl	48

GA28-17A-100

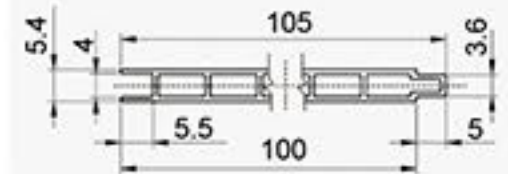

kg/m	0.549
m/Pc	4
m/Bdl	48

GA28-18A-50

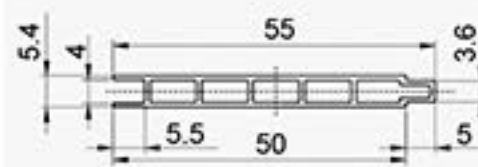

kg/m	0.283
m/Pc	4
m/Bdl	48

GA28-19A-30

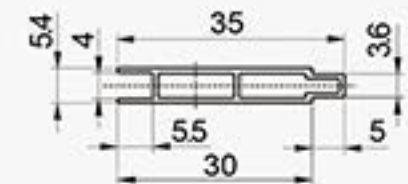

kg/m	0.170
m/Pc	4
m/Bdl	48

GAJ28-B05

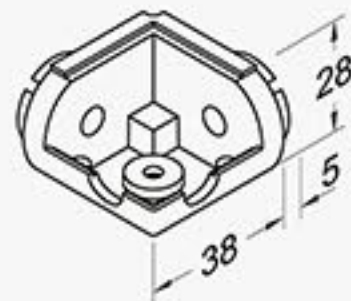

kg/Pc	0.042
Pc/Ctn	000

GAE28-46

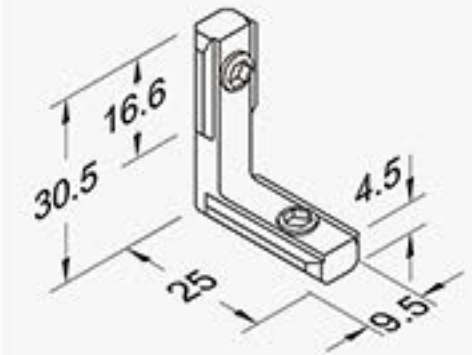

kg/Pc	0.000
Pc/Ctn	000

GAP28-19

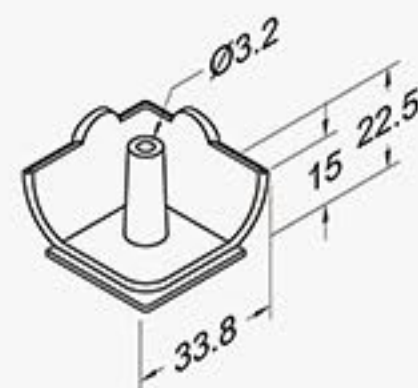

kg/Pc	0.104
Pc/Ctn	130

GAP28-20

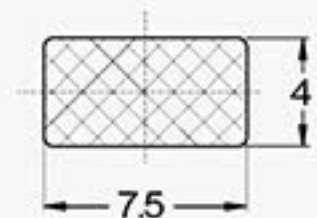

kg/Pc	0.100
Pc/Ctn	120

Pallet system assembly

1 Main Frame

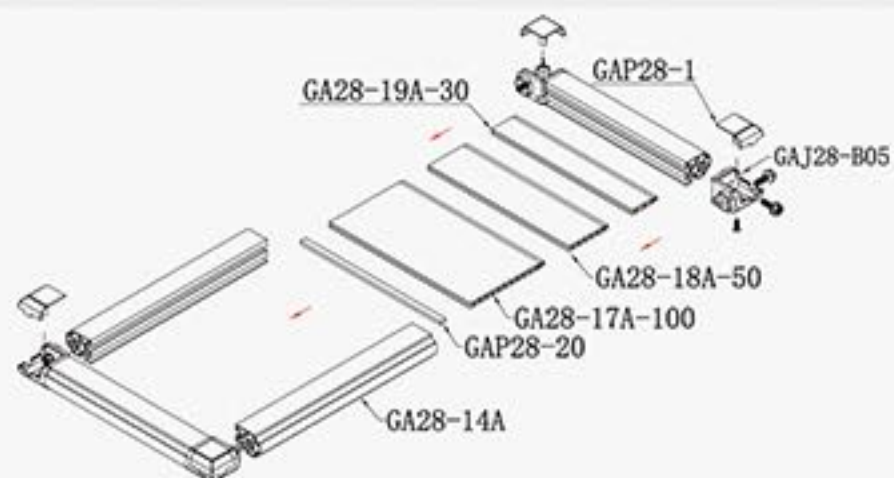

2 Pallet Separate Type Assembly



3 Dimension Select Method

$$A=L-76 \quad A=L2-5$$

$$X=W1+12 \quad X=B+12$$

$$Y=L2+12 \quad Y=A+12$$

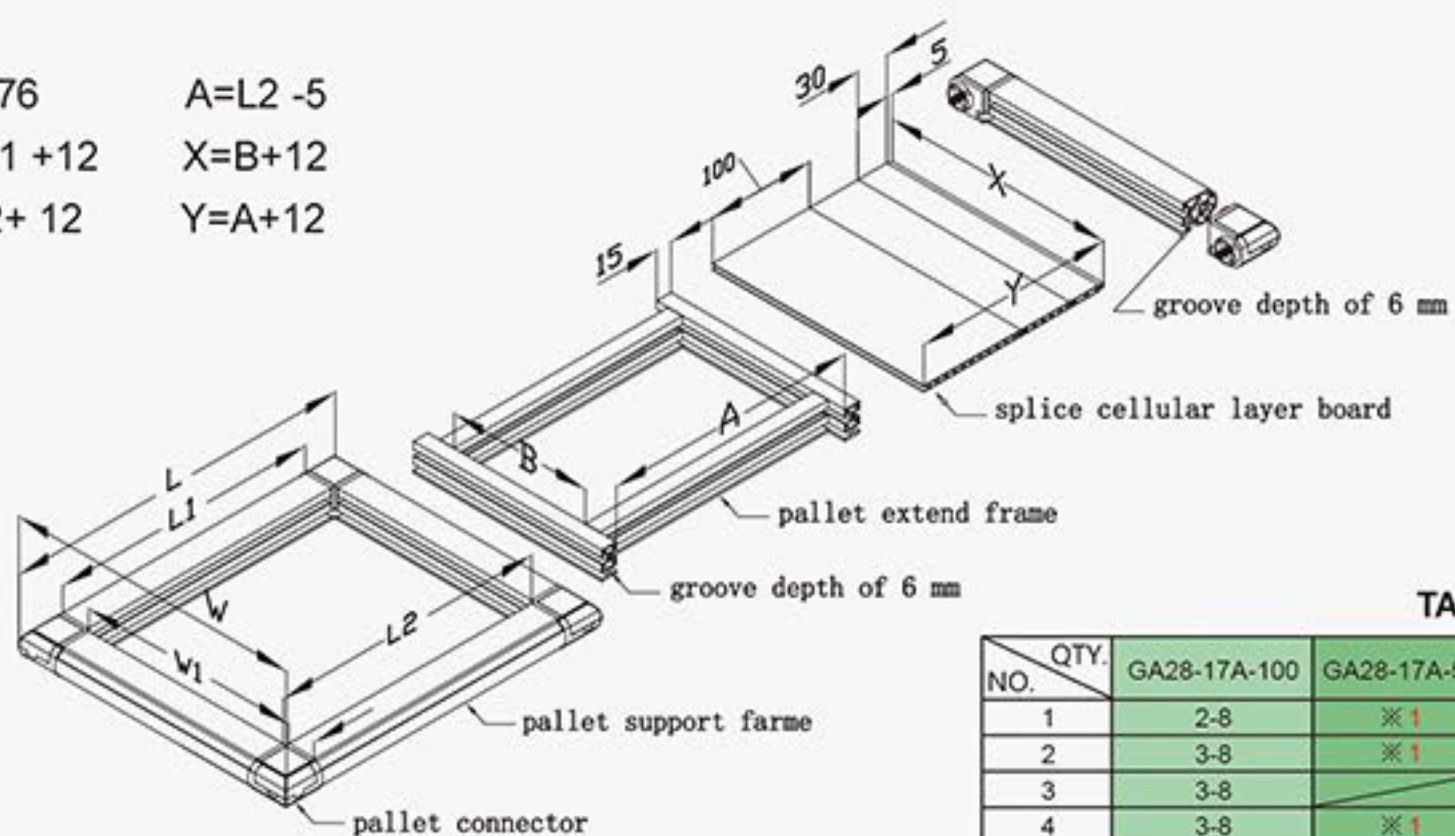

- ※ Layer board width three kinds of cellular layer board +5mm
- ※ When Pallet connector connected with pallet support frame, Please use the outer hexagon socket with electricity tool to lock the tapping screw and set the torque to 8~10N/m

TABLE

NO.	QTY.	GA28-17A-100	GA28-17A-50	GA28-17A-30	L2 / W1 (mm)	L / W (mm)
1	2-8		※ 1	※ 3	333 - 1133	403 - 1203
2	3-8		※ 1		343 - 1143	413 - 1213
3	3-8			※ 2	353 - 1153	423 - 1223
4	3-8		※ 1	※ 1	373 - 1173	443 - 1243
5	3-8			※ 3	383 - 1183	453 - 1253
6	4-8				393 - 1193	463 - 1263
7	3-8		※ 1	※ 2	403 - 1203	473 - 1273
8	3-8			※ 4	413 - 1213	483 - 1283
9	4-8			※ 2	423 - 1223	493 - 1293

※ FIXED QTY.

4 Frame assembly method



5 Hoisting assembly method

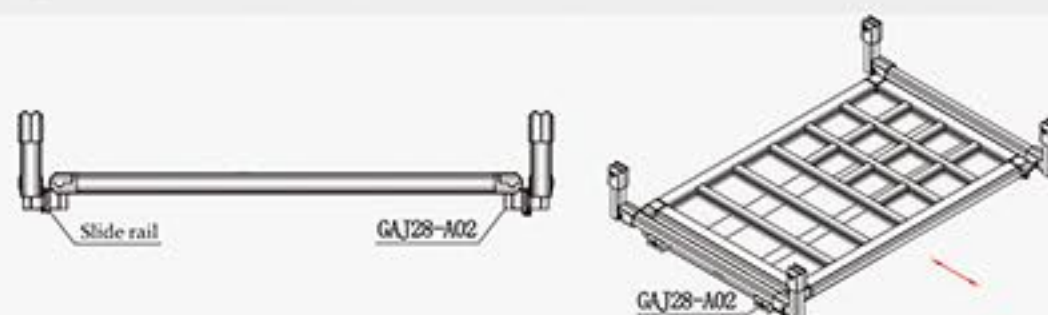

6 Application

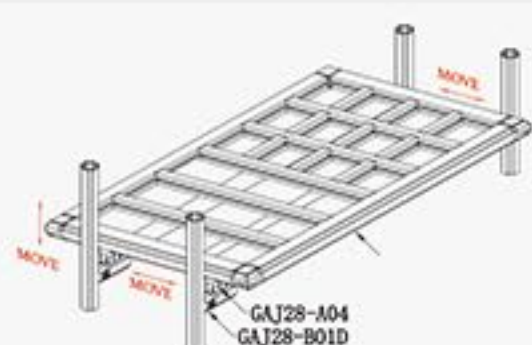

Pallet horizon assembly

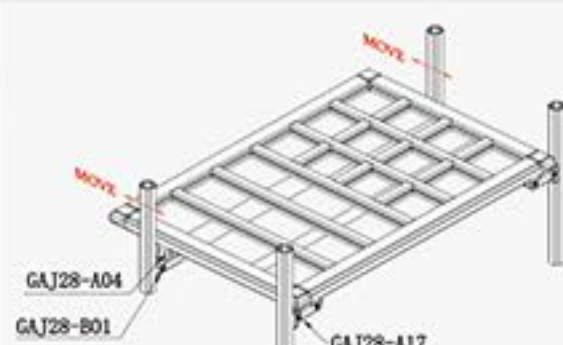

Pallet vertical assembly



Shelf



Trolley